

TELESCOPIC CYLINDER
 FRONT MOUNTED COVER - TRUNION
 TIPPING WEIGHT: 60-89 ton / 132-196 x 1000 lbs

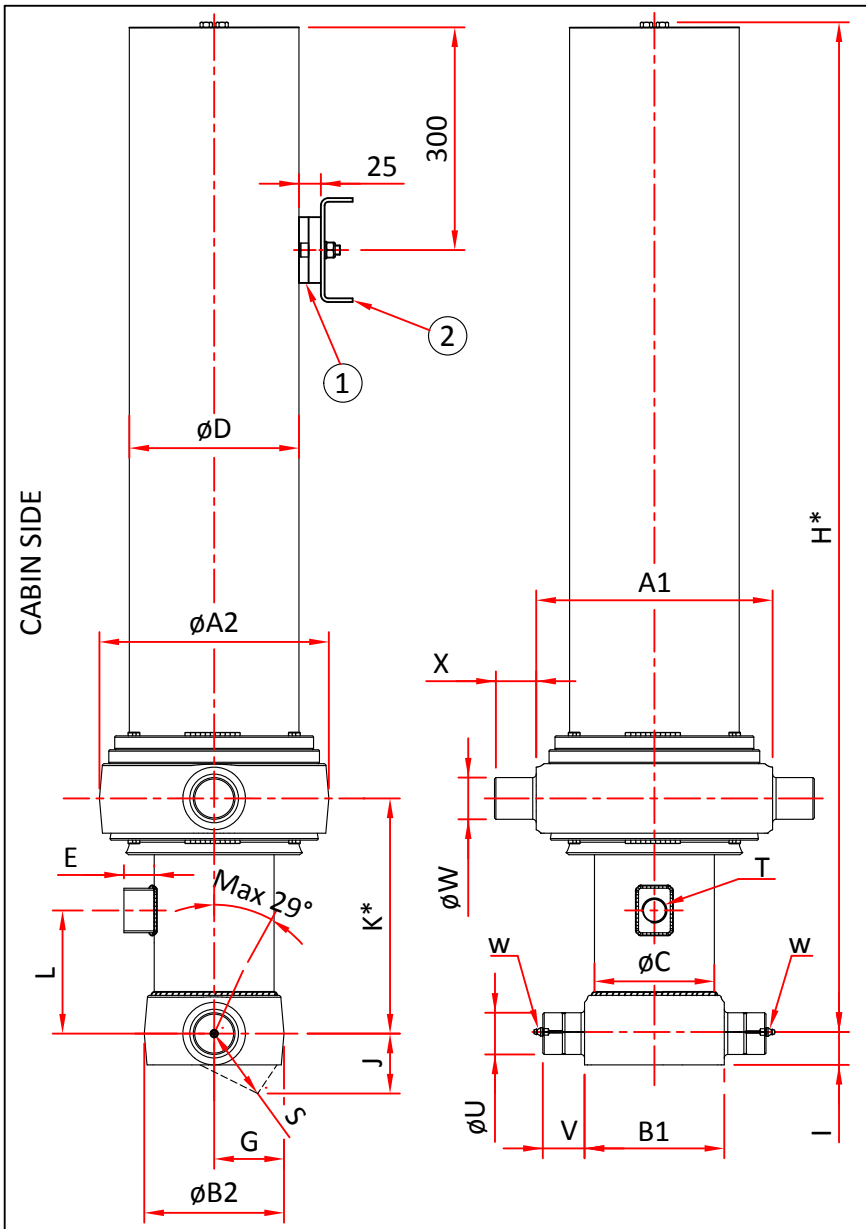

Part Number	Cylinder Type	Stroke Length	Dry Weight of Cylinder	Working Volume	Total Volume	Max. Pressure	Max. Pump Flow	Max. Thrust first stage
10015714C	FMCT 215-7085/5/C	279"	1063 lbs	45 gallon	48 gallon	2466 psi	28 gal/min	136686 lbs
		7085mm	482 Kg	169L	180 L	170 bar	107 L/min	62 ton

Stage	1	2	3	4	5	6	Total
Stage Diameter (inch)	8,4	7,5	6,7	5,9	5,1		
Stage Diameter (mm)	215	192	170	150	130		
Stroke (inch)	47,0	47,8	47,8	47,8	47,8		279
Stroke (mm)	1194	1214	1214	1214	1214		7085



	U.S.	Metric	Units
A1	14,17"	360	mm
A2	12,99"	330	mm
B1	10,62"	270	mm
B2	10,74"	273	mm
C	9,40"	239	mm
D	10,74"	273	mm
E	1,33"	34	mm
G	5,39"	137	mm
H*	65,07"	1653	mm
I	3,34"	85	mm
J	5,23"	133	mm
K*	13,50"	343	mm
L	7,48"	190	mm
S	5,94"	151	mm
T	1"	1"	BSP
U	2,55"	65	mm
V	2,55"	65	mm
W	2,36"	60	mm
X	2,36"	60	mm

T - Oil Inlet Port
 * incl. 0,79" [-0,2;1,2"] / 20[-5;30]
 pullout on piston

Note :

- > C - Hard Chrome Plated.
- > w - Grease nipple M8x1P - 2 nos. (Base trunion)
- > 20mm Clearance must be maintained between cylinder bottom and cradle or King pin - dimension J=133mm.
- > Anti rattle rubber (1) should be touching the cylinder cover as shown.
- > Bracket (2) to be welded to the head board or head board stiffener.
- > We recommend to use Hypratek Chassis brackets and Lifting brackets.
- > Dimensions subject to change without notice.
- > Please turn over this page to see the mounting instructions and Tipping weight to Tip angle.